



Warning!
Flat glass units are heavy.
Some units may require a mechanical lift

Vented or Unvented direct fix on existing upstand

For Mardome Glass Trade on a 150 mm or 300mm kerb

See **Page 2** overleaf

Contents

i Please unpack and check that all correct parts are included and undamaged.

Mardome Glass Trade (Unvented or Vented)

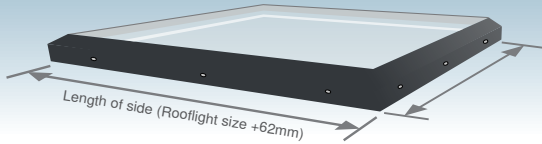

Plus, for Vented Version Only

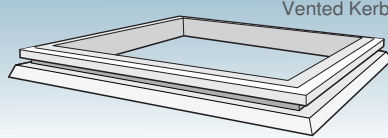

With this assembly, you will receive:
Glass Unit Fixings

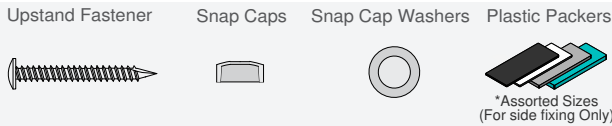

For Unvented assembly:

For vented assembly, you will receive:

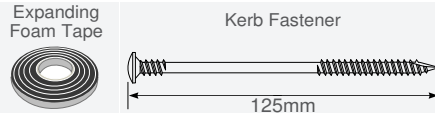

Fixing Quantities - Kerb

Length of Nominal Unit Side (mm)	Number of fixings per side
600, 750	2
900, 1050, 1200	3
1350, 1500, 1650	4
1800, 1950	5
2100, 2250	6
2400	7

(All fixings supplied in packs of 5.)

Fixing Quantities - Glass Unit

Length of Nominal Unit Side (mm)	Number of fixings per side
< 900	2
> 901, < 1500	3
> 1501, < 2000	5
> 2001	7

(fixings supplied in packs of 4.)

Installation

i Please note that all Health and Safety Regulations must be followed on site throughout the installation process.

Mardome Glass Trade Unvented on to existing upstand

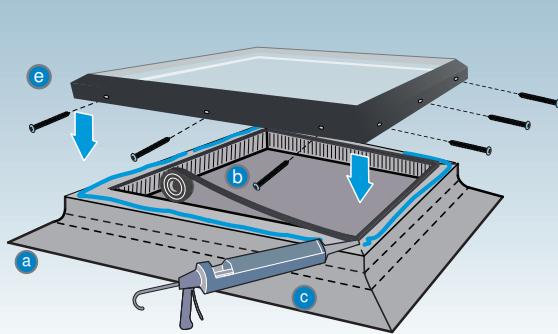

Mardome Glass Trade Vented onto existing upstand

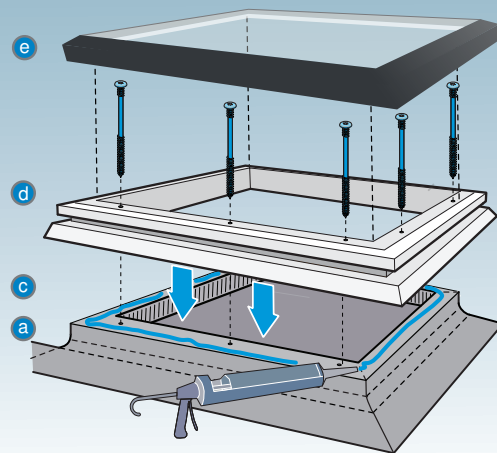

Fixing to Upstand

NOTE: Upstand external dimensions for this unit are: Nominal Rooflight size +20mm/-0mm

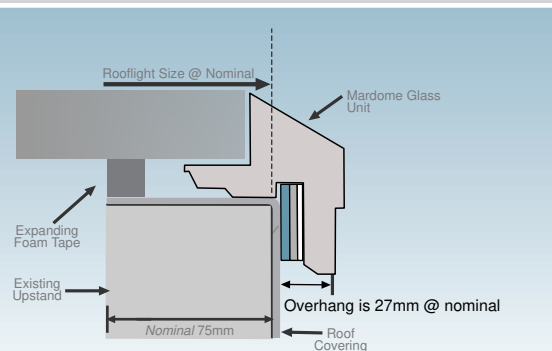

Vented Kerb Fixing

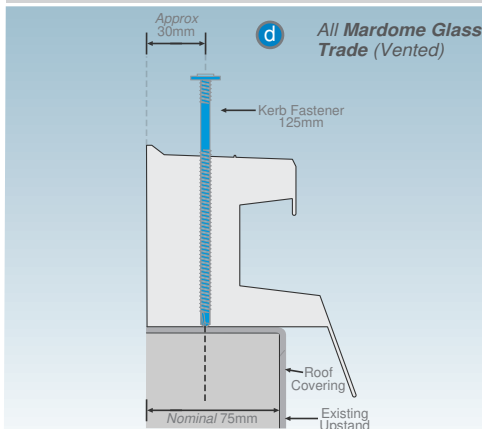

Fixing to Vented Kerb

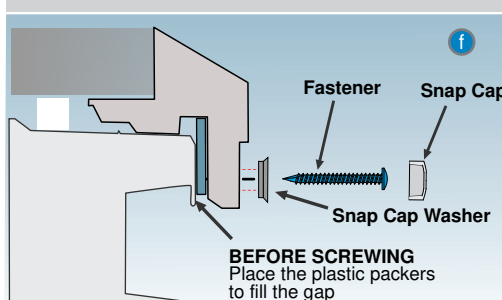

Installation Instructions

a Install roof covering to cover existing upstand in accordance with manufacturer's installation recommendations.

N.B. It is important that there should be no excessive build up of layers, the top surface should be level and free from any protrusions or projections which may prevent adequate weather proofing.

***For Vented Version go to c**

b For Non Vented Version: Apply expanding foam tape around the inside edge of the upstand.

c Mastic/Silicone around the outside edge of the upstand opening.

***For Non Vented Version go to e**

d For Vented Version: Correctly place vented kerb, ensuring it is located squarely to the upstand. Fix vented kerb to the existing upstand using the 125mm vented kerb fastener.

e Correctly place glass unit squarely on top of the completed upstand/secured vented kerb ensuring even gap on all sides

f Fix the glass unit to the vented kerb or existing upstand.

Use the supplied unit fasteners through the nylon washer

BEFORE SCREWING in the fastener, place the plastic packers to fill the gap between the frame and the upstand/vented kerb.

AFTER SCREWING fit snap caps over the head of each fastener.

TECHNICAL SUPPORT: For any technical information/queries please contact your supplier.



Warning!
Flat glass units are heavy.
Some units may require a mechanical lift

Contents

i Please unpack and check that all correct parts are included and undamaged.



For **Mardome Glass Trade**
Vented or Unvented direct
fix on existing upstand
See **Page 1** overleaf

With this assembly, you will receive:

Glass Unit Fixings				Kerb Fixings
Upstand Fastener	Snap Caps	Snap Cap Washers	Plastic Packers	Kerb Fastener
			 *Assorted Sizes (For side fixing Only)	 55mm

Fixing Quantities - Kerb

Length of Nominal Unit Side (mm)	Number of fixings per side
600, 750	2
900, 1050, 1200	3
1350, 1500, 1650	4
1800	5
2400	7

(Fixings supplied in packs of 5.)

⚠ Please note that all *Health and Safety Regulations* must be followed on site throughout the installation process.

⚠ Please note that all *Health and Safety Regulations* must be followed on site throughout the installation process.

Installation

Installation

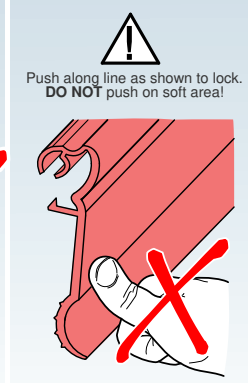
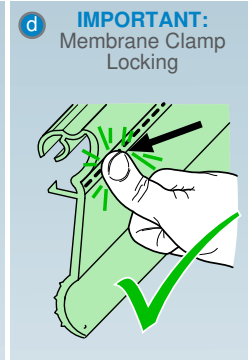
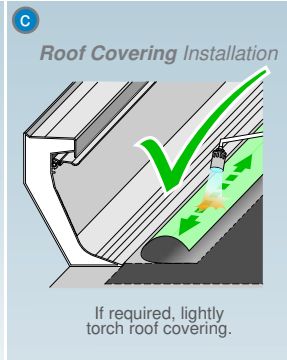
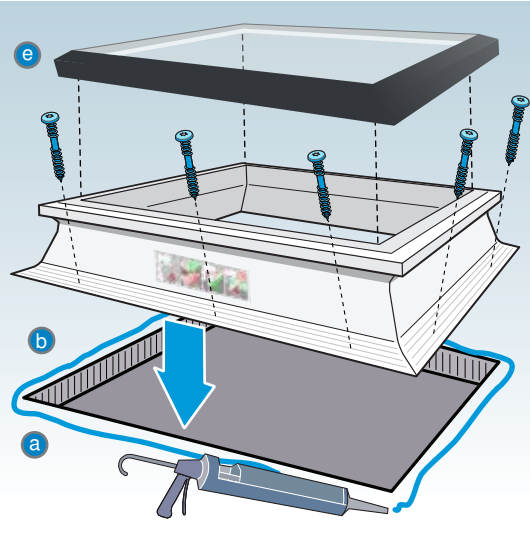

Fixing Quantities - Glass Unit

Length of Nominal Unit Side (mm)	Number of fixings per side
< 900	2
> 901, < 1500	3
> 1501, < 2000	5
> 2001	7

(Fixings supplied in packs of 4.)

Installation Instructions

- a** Mastic/Silicone around the edge of the roof opening and correctly place kerb, ensuring it is located squarely to the upstand.
- b** Fix kerb to the roof using the 55mm kerb fastener.

See above **Fixing Quantities - Kerb** table for the correct quantity of fastenings required for the size of the glass unit.

N.B. Length of side refers to the nominal glass unit size (equivalent to inside base of kerb foot).
- c** Install roof covering up to lip, to stop under membrane clamp, ensuring it **does not** foul clamp. Install in accordance with manufacturer's installation recommendations.

N.B. **Never** apply direct heat or naked flame to the rooflight! Ensure the roof covering **does not** foul clamp!

Kerb Installation

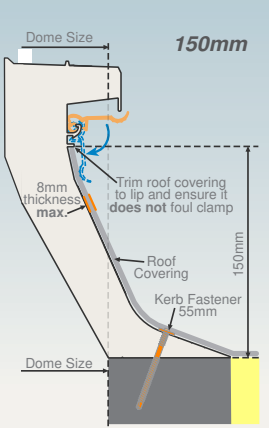
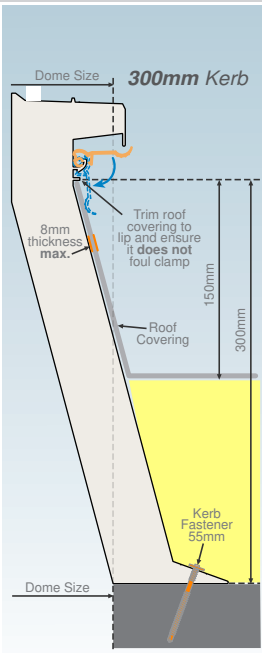
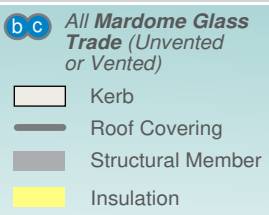

Fixing to Vented Kerb

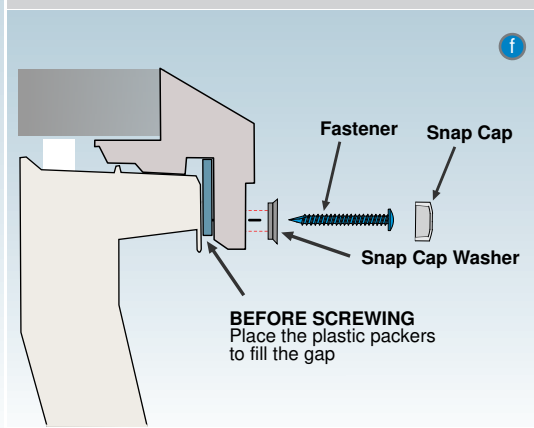

- d** Lock the membrane clamp down fully, as shown.
- e** Place glass unit squarely on top of the secured kerb ensuring even gap on all sides.
- f** Fix the glass unit to the kerb

Use the supplied unit fasteners through the nylon washer. Only screw through pre drilled holes.

BEFORE SCREWING in the fastener, place the plastic packers to fill the gap between the frame and the kerb.

AFTER SCREWING fit snap caps over the head of each fastener.