

ARENA

DECKING SUBFRAME

PLASTIC JOISTS & POSTS INSTALLATION

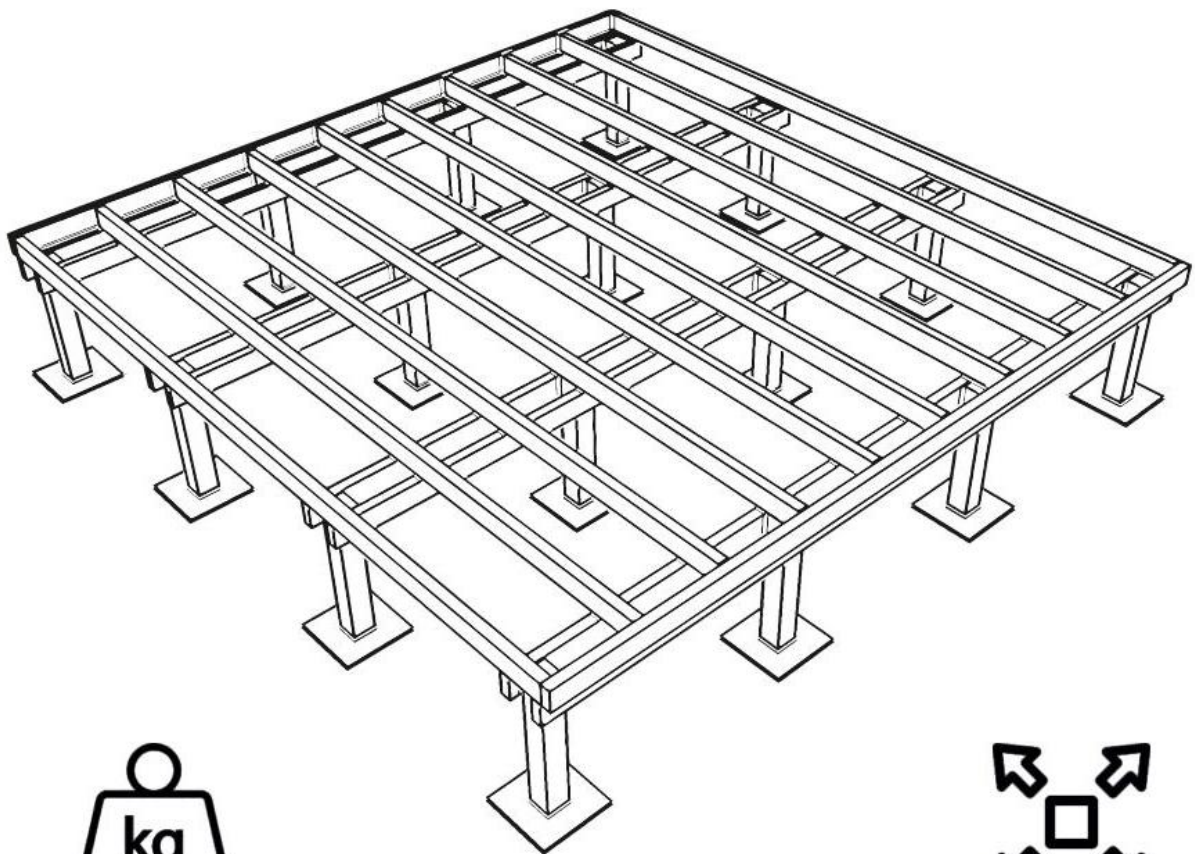

Load bearing
capacity
120 kg/joists

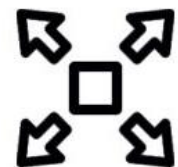

Expansion rate:
0-20 Celsius
+/- 4mm

1. Fix your Posts in the ground

Once your area is cleared and prepared, mark a grid layout. You can use our 80x80 mm square posts (for a lower deck) or 100x100 mm square posts (for a higher deck), cut to the necessary length. Make sure that the posts are at 1,000 mm intervals. This is the maximum support span of the plastic joists.

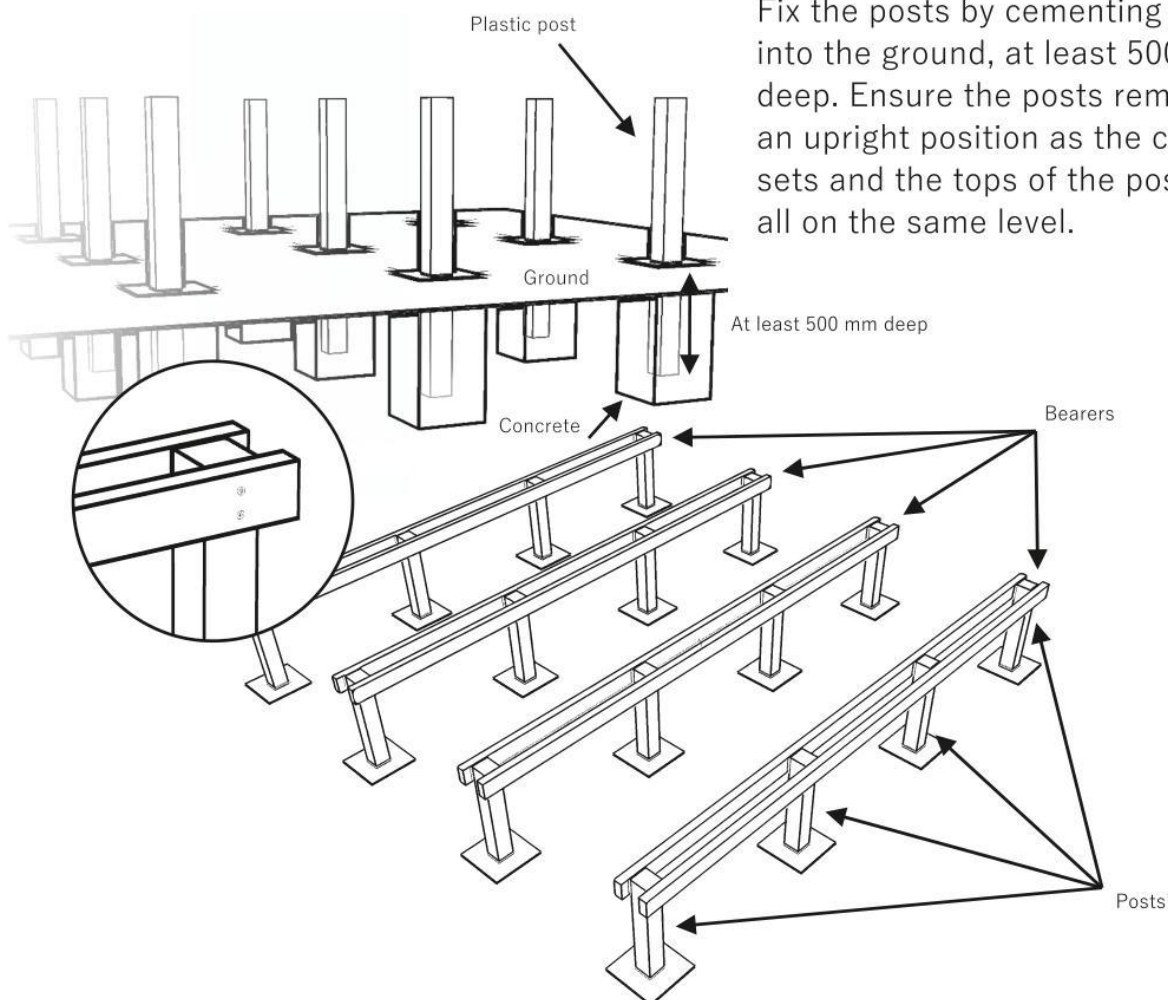
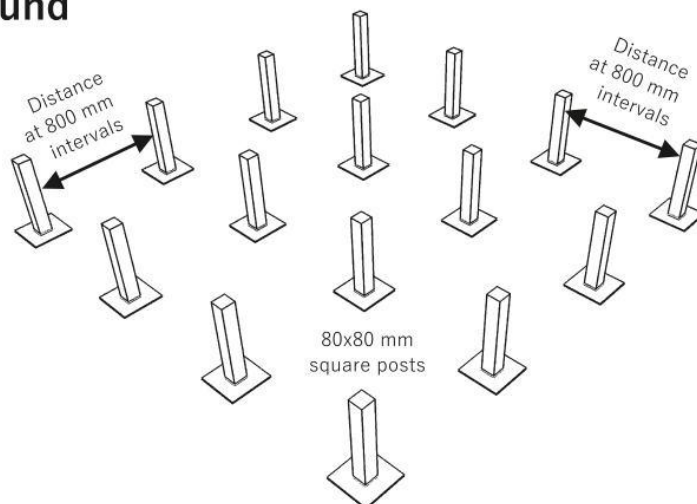

Fix the posts by cementing them into the ground, at least 500 mm deep. Ensure the posts remain in an upright position as the concrete sets and the tops of the posts are all on the same level.

2. Fix the first plastic joists to create a subframe support

Fix the bearers along the length of posts, providing structural support for your joist. When fixing the bearers to the posts, a gap of 90 mm should be left above the bearer in order to accommodate the thickness of the joist.

3. Securing the Bearers

The bearers must be supported by a post. Make sure that you have an expansion gap of 10 mm between the bearers. Use 6 mm (for smaller posts) or 10 mm (for larger posts) External Timber Frame Construction & Landscaping Screws. Make sure that they are not self-cutter screws. Fix the frame to every post securely. Pre-drill the joists with an oversized pilot hole, approximately +3 mm. Use HSS drill bits.

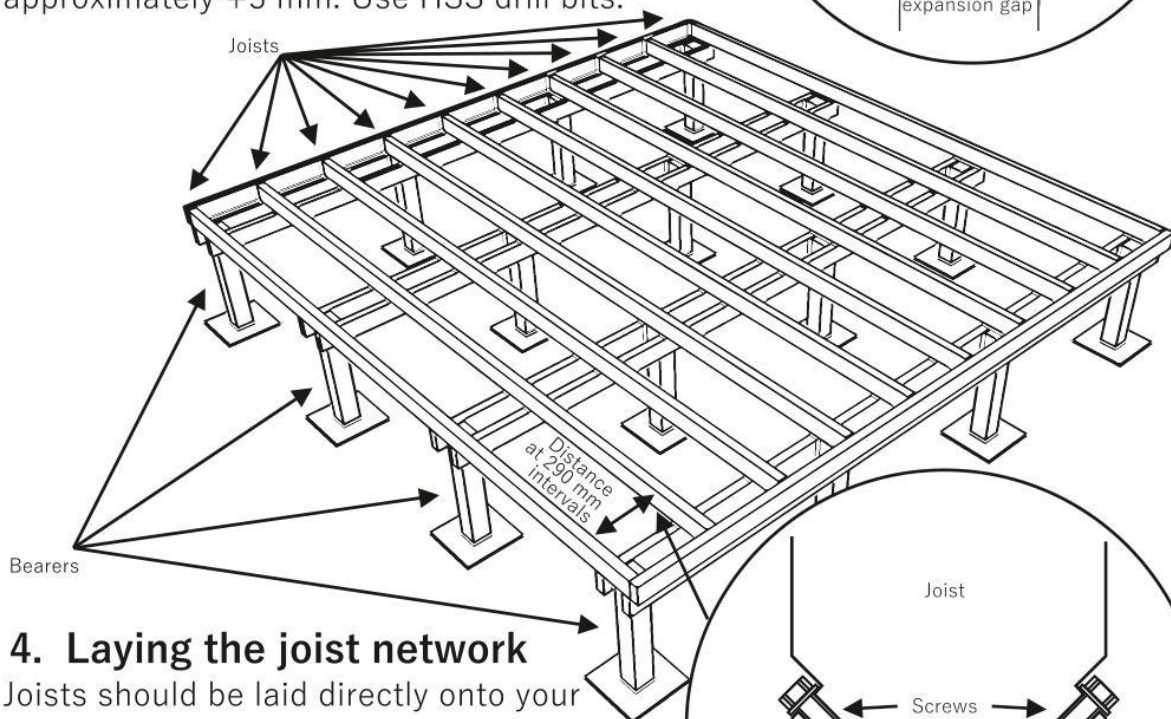
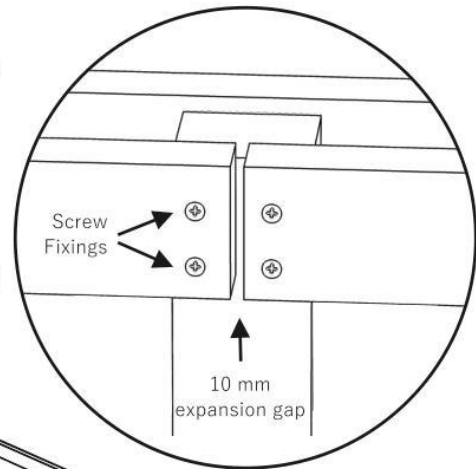

4. Laying the joist network

Joists should be laid directly onto your bearers in accordance with the recommended spacing of 250–350 mm. Begin by installing the outside joists to the subframe and continue fixing along the decking bearer network.

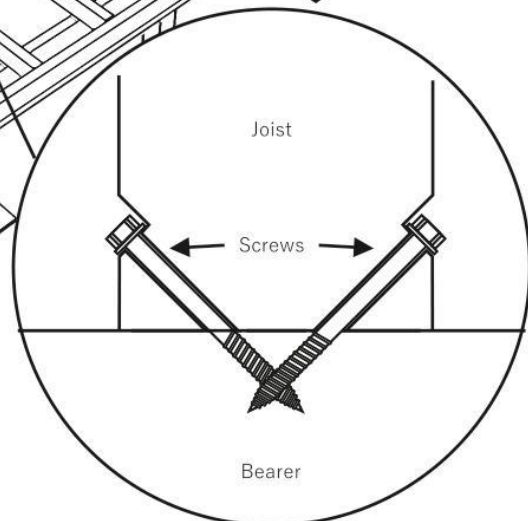

5. Fixing the joists

Fix the joist into the bearers. Use a 6x100 mm or 10x100 mm single thread External Timber screw to ensure proper fixing and pre-drill the material with an oversized pilot hole, approximately +3mm larger than the screw. Use HSS Drill bits. As an additional support, you can fix noggins between the joists. When joining two joists, ensure an expansion gap of 10 mm is left. Where two boards are expected to meet, ensure sufficient support is provided in the form of a double joist.

Always make sure that you do not leave plastic sawdust behind, remember, this material will be there for a long time.